

Snorkel

SL 20

The narrow width of these machines allows them to fit through most standard doorways, and the wide variety of standard features makes them ideal for slab-type construction, building renovation, or maintenance work of all types.



S P E C I F I C A T I O N S

Working Height	26'	7.9 m
Platform		
Height	20'	6.1 m
Capacity*	800 lbs.	363 kg
Size	30" x 90"	76 x 229 cm
Guardrail Height	41"	104 cm
Toeboard Height	6"	15 cm
Stowed Platform Height	37 ¹ / ₂ "	95 cm
Stowed Overall Height	78 ¹ / ₂ "	199 cm
Overall Width	33"	84 cm
Overall Length	91"	231 cm
Wheelbase	74"	188 cm
Turning Radius		
Inside	30"	76 cm
Outside	101"	257 cm
Gradeability		20%
Drive Speed		
Speed No. 1 Elevated	0.4 mph	0.6 kph
Speed No. 2 Stowed	1.2 mph	1.9 kph
Speed No. 3 Stowed	2.1 mph	3.4 kph
Platform Lift Speed		20 sec. minimum
(3 speed control)		
Ground Clearance (Approx.)		
Platform Stowed/Pothole Protector Raised	3 ¹ / ₄ "	8.3 cm
Platform Raised/Pothole Protector Lowered	3 ³ / ₄ "	1.9 cm
Tire Size		4 x 16
Type		Solid Rubber
Weight (approx.)	3,750 lbs	1,701 kg
Shipping Cube		
With Guardrails	139 ft. ³	3.9 m ³

*Rated load on roll-out extension deck is 250 lbs. (113 kg)

- Automatically activated pothole protection
- Built-in level sensor interlocks
- Fits through most standard doorways
- 3' roll-out extension
- Printed circuit board with on-board LED diagnostics
- Joystick with finger-grip control on removable console
- Responsive center pivot-type steering
- 3-speed drive/3-speed lift
- Dual wheel drive system
- Drive motion alarm
- 2-wheel parking brakes
- Built-in scissor arm safety support
- Drivable at full work height
- Swing-out trays for batteries and hydraulics
- Lift out battery tray
- Non-marking tires
- Battery powered with built-in smart charger
- Forklift loadable from 3 sides
- 60 month factory warranty

Snorkel

SL 20

Narrow Slab SCISSORS

Optional Equipment

- Swinging gate
- 125 volt GFCI AC outlet at platform
- D-Ring lanyard attachments
- Operator horn
- Flashing light
- Battery condition indicator
- AC generator
- EE Rating
- 240 Amp/hr battery

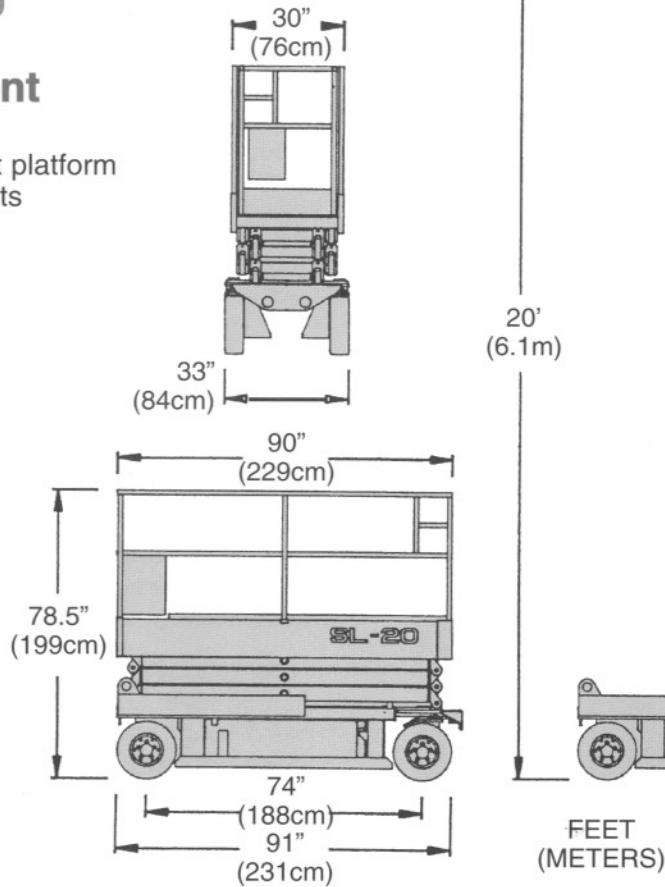

DANGER: Models described in this brochure are NON-INSULATED and do not provide electrocution protection from contact with or close proximity to energized conductors which is pointed out on decals and placards attached to the machine.

Only qualified and trained operators are to be authorized to use and operate a work platform.

Aerial work platforms must be elevated only on firm, level surface.

Products in this brochure comply with applicable ANSI Standards. This literature is for illustrative purposes only. Consult Operating/Maintenance and Parts Manuals for proper procedures. Specifications may vary and are subject to change without notice or obligation.

OmniQuip Snorkel

P.O. Box 1160
St. Joseph, MO 64502-1160
816-364-0317 ♦ Fax: 816-364-0380

An ISO 9001 Registered Company

www.snorkelusa.com

Printed in U.S.A.
SL-20 1-99