

Snorkel

Snorkelift®

TBA 420

700 lb. platform capacity combined with smooth, precise controls and proven reliability make these the machines of choice for most heavy-duty applications.



S P E C I F I C A T I O N S

Working Height	48'	14.6 m
Platform		
Height	42'	12.8 m
Capacity	700 lbs.	318 kg
Size	60" x 30"	152 x 76 cm
Construction	High strength aluminum	
Boom Construction		
Base Boom	Steel	
Telescoping Booms	High strength aluminum	
Boom Extension	Double acting hydraulic cylinder and dual wire rope cables	
Boom Guides	Lubrication free, ultra high molecular weight polyethylene	
Pivot Pin Bearing	Lubrication free, composite material	
Horizontal Reach	33'	10.1 m
Elevation	+75°/-18°	
Hose & Wiring Extension	Telescoping housing attached to sides of booms	
Turntable Rotation	360° continuous	
Power Source	Gas or Diesel engine standard, Dual Fuel or LPG optional	
Fuel Capacity	20 U.S. gal.	75.7 L
Hydraulic System Capacity	25 U.S. gal.	94.6 L
Maximum Drive Speeds		
Booms Stowed	3 mph	4.8 kph
Booms Elevated	1 mph	1.6 kph
Gradeability	25%	
Turning Radius (Inside)	5'2"	1.6 m
Stowed Height	7'9½"	2.4 m
Width	7'11½"	2.4 m
Stowed Length	23'6¼"	7.2 m
Wheel Base	8'	2.4 m
Tires	12" x 16.5"	
Type	10 ply rating	
Weight (approx.)	11,150 lbs.	5,058 kg

- Fully proportional ramp-on controls for boom lift, swing, and drive
- Automatic braking
- 180° hydraulic platform rotation
- 12 volt battery operated emergency power
- Manual bleed down valve
- Driveable at full height
- 5° tilt alarm
- 110 volt AC outlet at platform
- Aluminum upper booms
- Hour meter and ammeter
- Engine anti-restart control
- Hydraulic oil level and temperature gauges
- High engine temperature and low oil pressure shut-down system
- 60 month warranty

Snorkel

Snorkelift®

TBA 420

Telescoping Boom

Optional Equipment

- Operator horn
- Platform control box cover
- Platform work lights
- GFCI AC outlet at platform
- Flashing light on boom
- Self-closing gate
- Sandblast protection kit
- Driving lights
- Dual fuel or LP gas only
- Spark arrestor muffler
- Cold weather start kit
- AC generator (hydraulic powered)
- Motion warning alarm
- Polyurethane filled tires
- Tow kit
- Four wheel drive
- Platform option
92" x 30" (234 x 76 cm) Alum.
(Capacity 650 lbs., 295 kg)

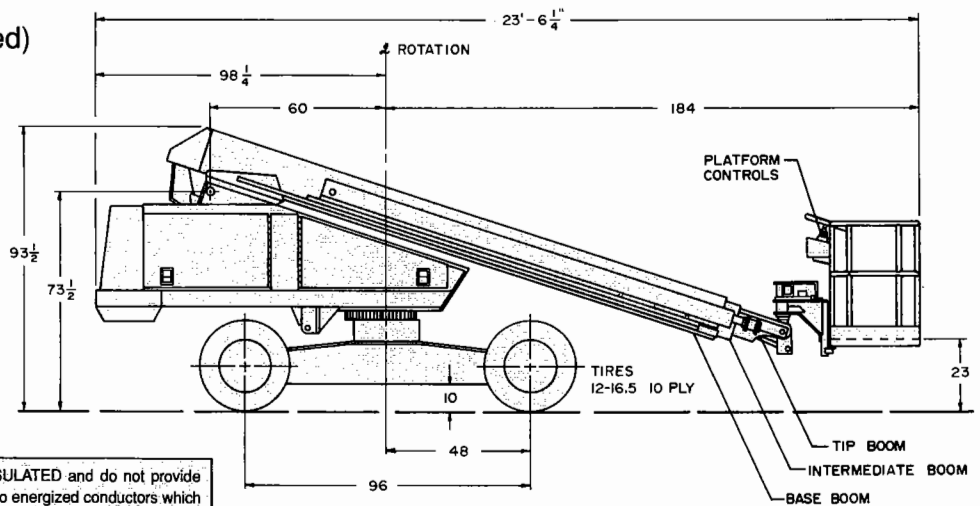
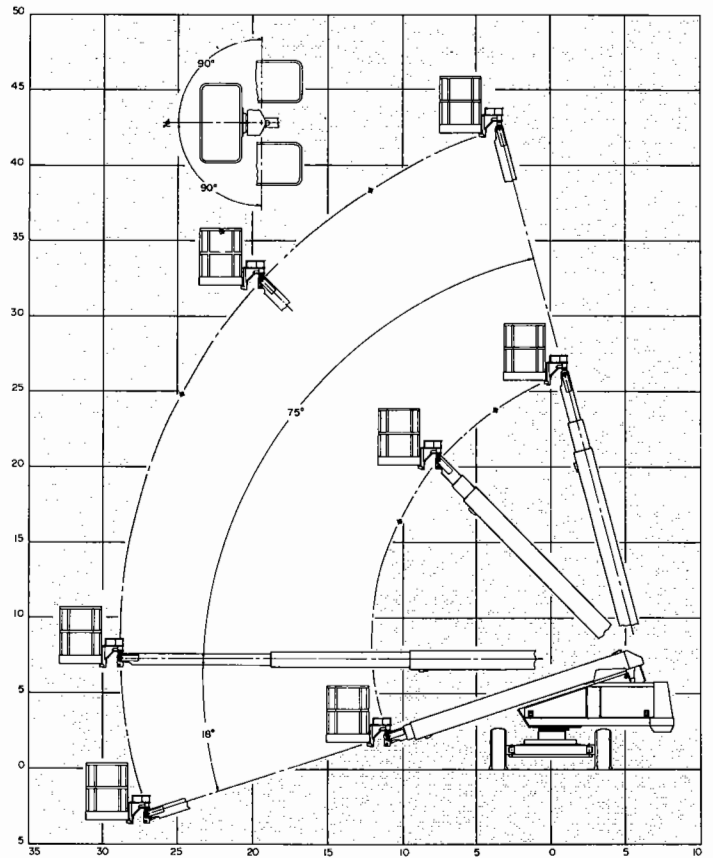

DANGER: Models described in this brochure are NON-INSULATED and do not provide electrocution protection from contact with or close proximity to energized conductors which is pointed out on decals and placards attached to the machine.

Only qualified and trained operators are to be authorized to use and operate a work platform.

Aerial work platforms must be elevated only on a firm, level surface.

Products in this brochure comply with applicable ANSI Standards. This literature is for illustrative purposes only. Consult Operating/Maintenance and Parts Manuals for proper procedures. Specifications may vary and are subject to change without notice or obligation.

Sales, Rental, Service by:

Snorkel

P.O. Box 4065, St. Joseph, MO 64504-0065

Phone: (816) 364-0317

FAX: (816) 364-0380